

Safety lighting for multifunctional industrial applications

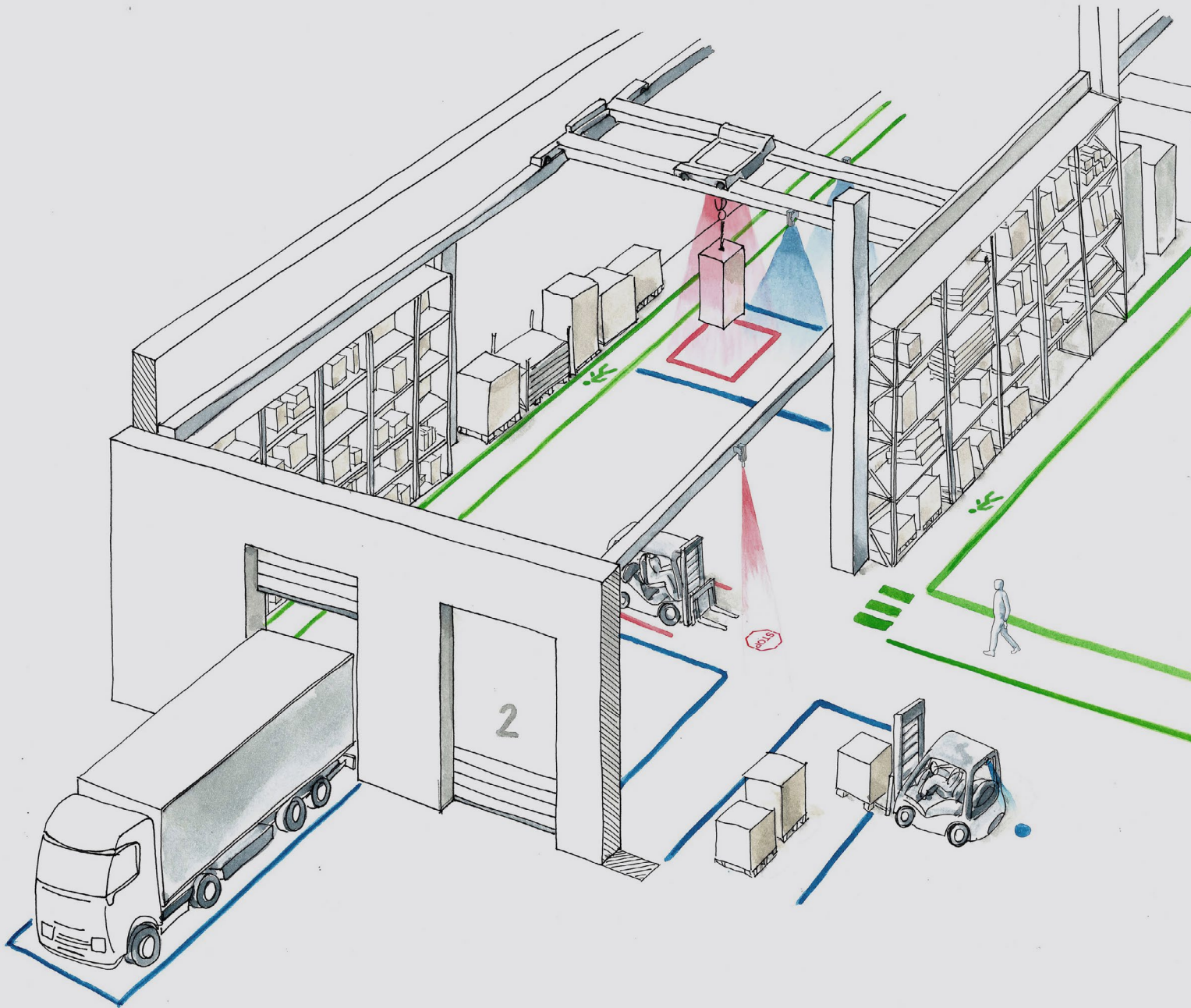

DESTTEVI®

the future will change with us

about us

DESTTEVI is an ITALIAN COMPANY specialized in the study, development, and production of INNOVATIVE SOLUTIONS FOR THE INDUSTRIAL AND CIVIL SAFETY LIGHTING SECTOR.

Patented products developed thanks to the experience and know-how of experienced and qualified engineers, in collaboration with university researchers.

DESTTEVI can count on the productive and consolidated potential of CS Group that over the years has distinguished itself as an important player in the industrial lifting sector.

mission

Offer cutting-edge, high-tech products designed **TO IMPROVE SAFETY AND EFFICIENCY** in a variety of sectors.

vision

Contribute to the **CREATION OF INCREASINGLY SAFETY ENVIRONMENTS.**
Encourage adopting technological innovation which surpass traditional solutions, optimize costs, and reduce waste.

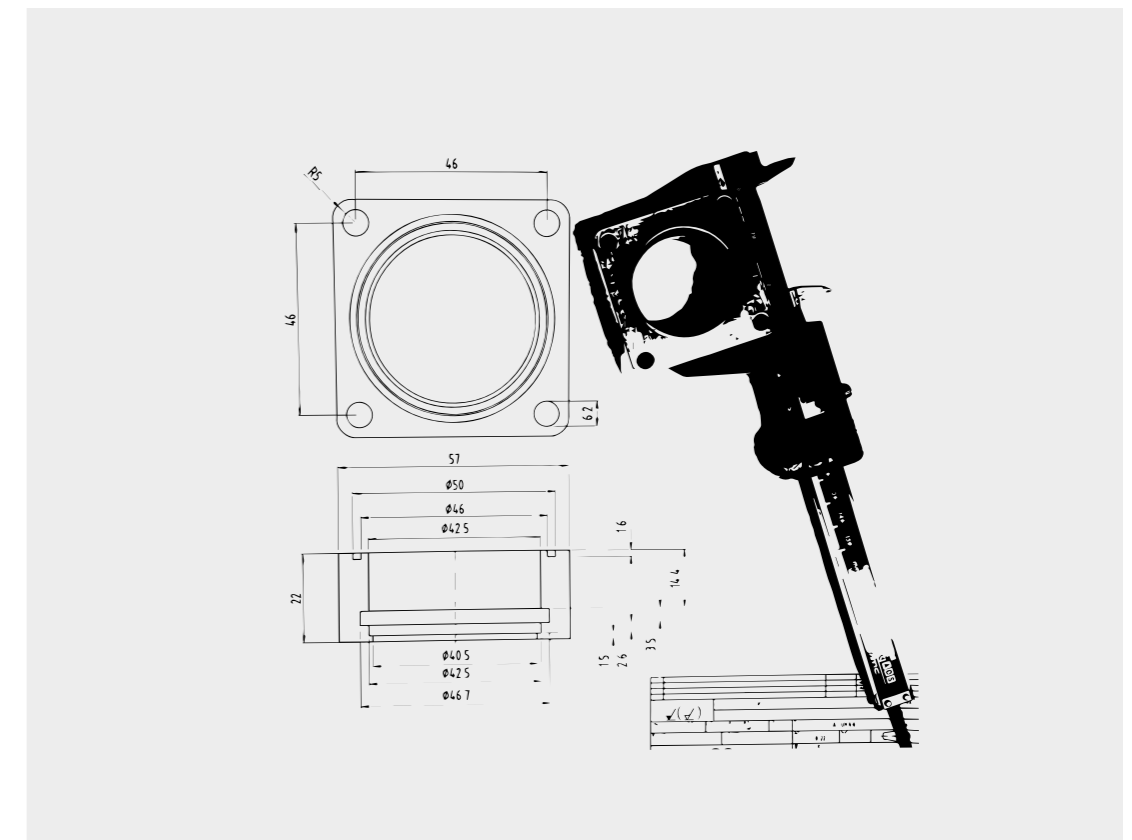

technological innovation

Choosing DESTEVI means investing in reliable and quality solutions, supported by a team of highly qualified and passionate specialists. Our goal is to offer our clients **INNOVATIVE AND CUSTOMIZED SOLUTIONS.**



Electronics detail

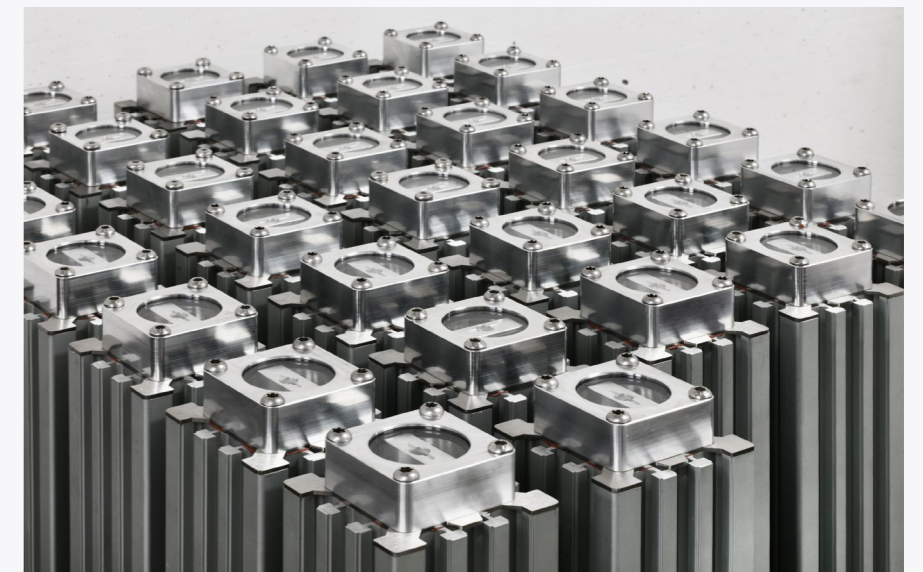
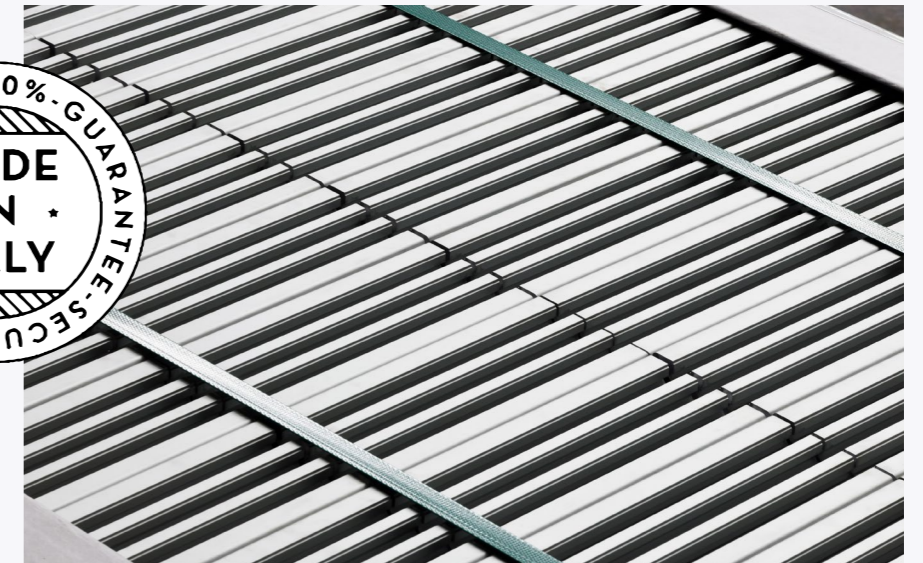

Performance and class 2 classification tests were performed on the projectors at the Polytechnic University of Milan.

We work with **PASSION AND DEVOTION** to meet different needs with design solutions made entirely in Italy. For instance, the power supply is integrated and the electronics are completely developed in-house. We are proud to offer **100% MADE IN ITALY PRODUCTS**, crafted with care and attention to detail.

light signal systems for industrial safety

DESTREVI has developed a collection of **INNOVATIVE PROJECTION SYSTEMS** for signaling light lines and symbols. Products designed specifically for **INDUSTRIAL APPLICATIONS** that may require reconfiguration of spaces and projections even over long distances.

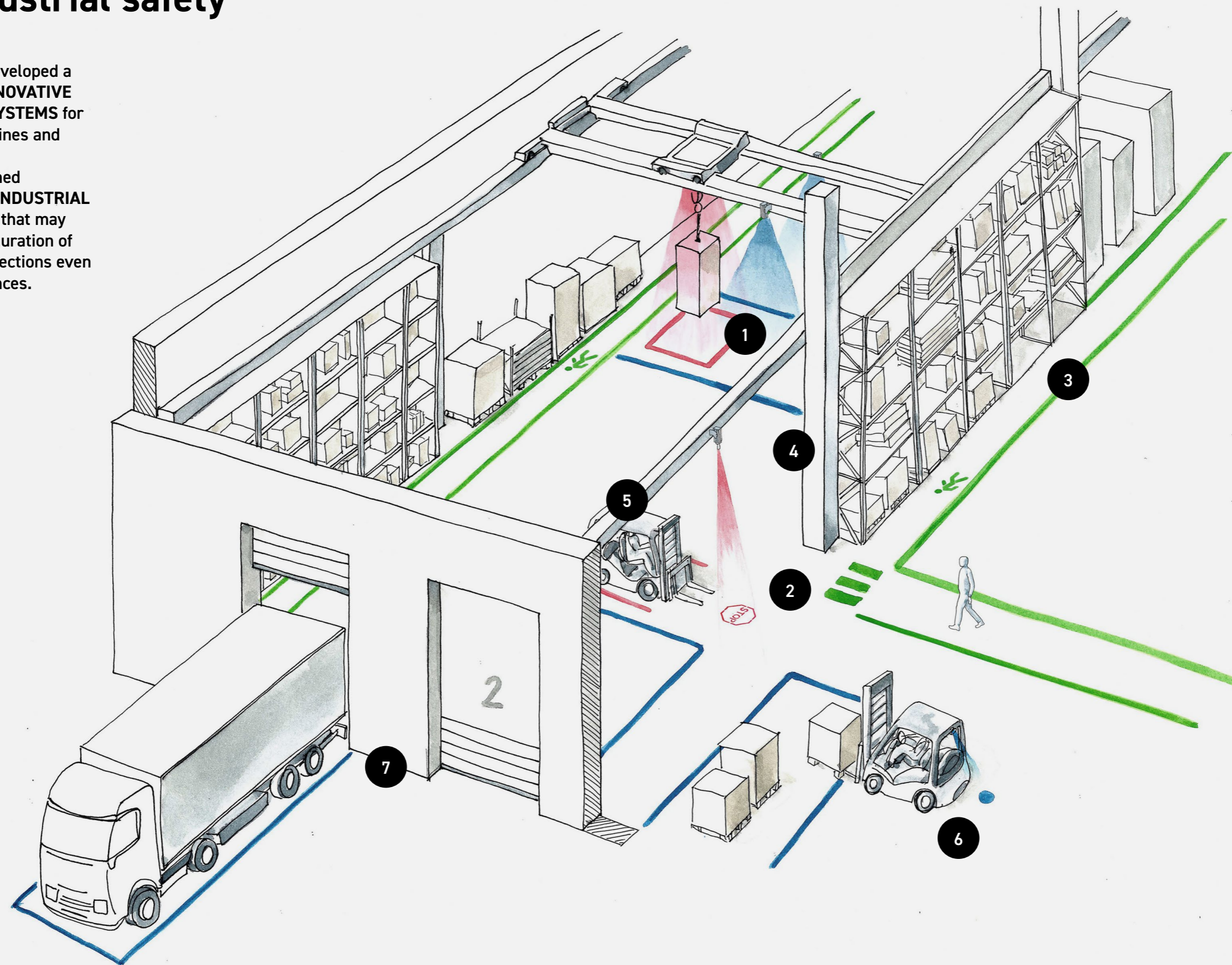

1
DELAS05 / DELAS SQUARE
line projectors
for overhead cranes and
moving elements

2
DEGOB / DEGOB240
symbol projectors for safety
signage

3
DELAS05
long line projector for
signalling footpaths or escape
routes

4
GENIUS
smart management systems for
dynamic projectors signage

5
DECARLINE
line projector for signalling
lift trucks in motion

6
DECARPOINT
point projector for signalling
lift trucks in motion

7
DELAS05 / DELED
long and short line projector
for signalling parking and
loading-unloading areas

applications for industrial signs

DESTEVI products are excellent projection systems for **OUTLINING AND MARKING AREAS OF UTMOST ATTENTION**, offering a valid alternative to traditional resin or paint signage systems.

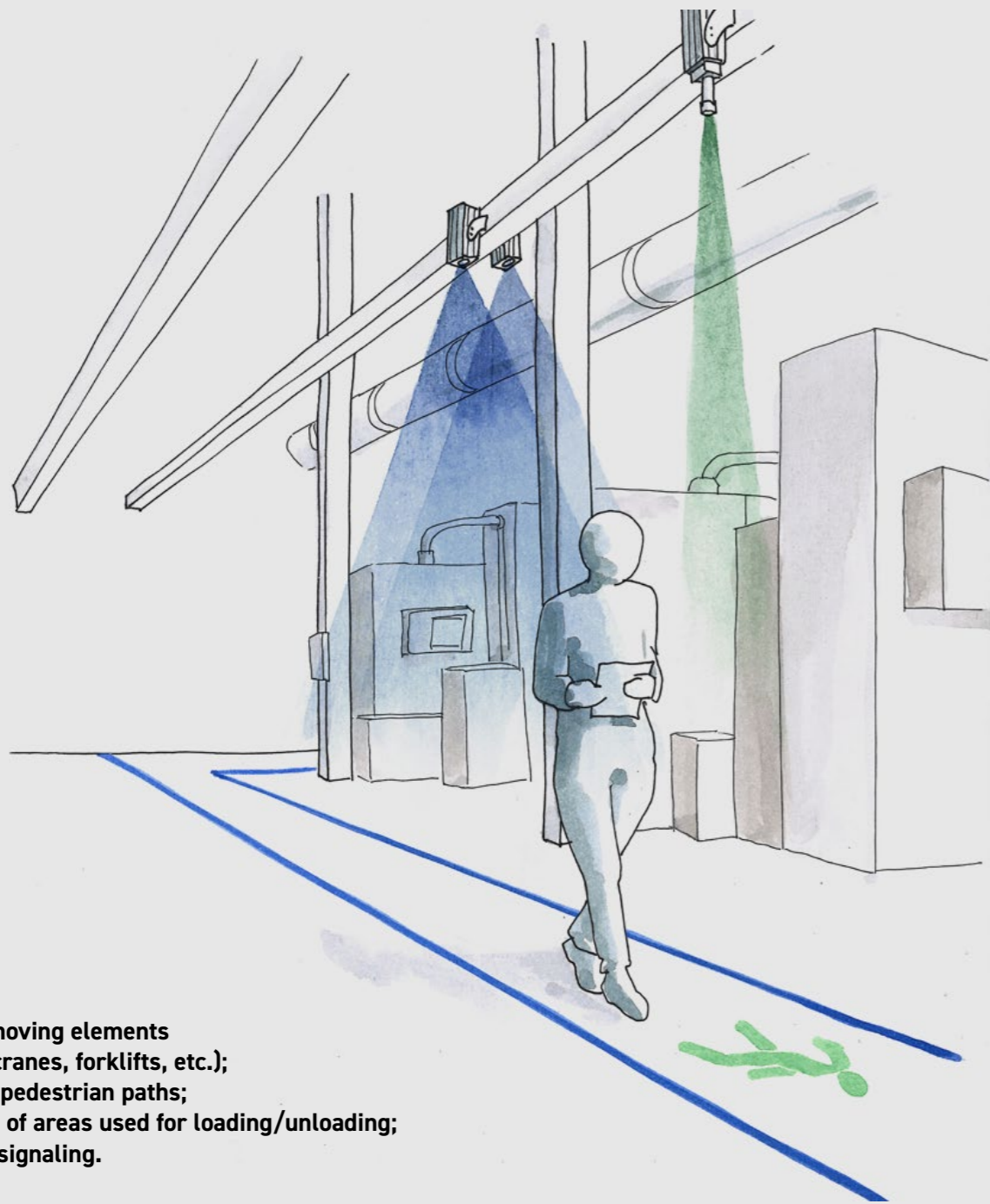

- Signaling moving elements (overhead cranes, forklifts, etc.);
- Marking of pedestrian paths;
- Delineation of areas used for loading/unloading;
- Horizontal signaling.

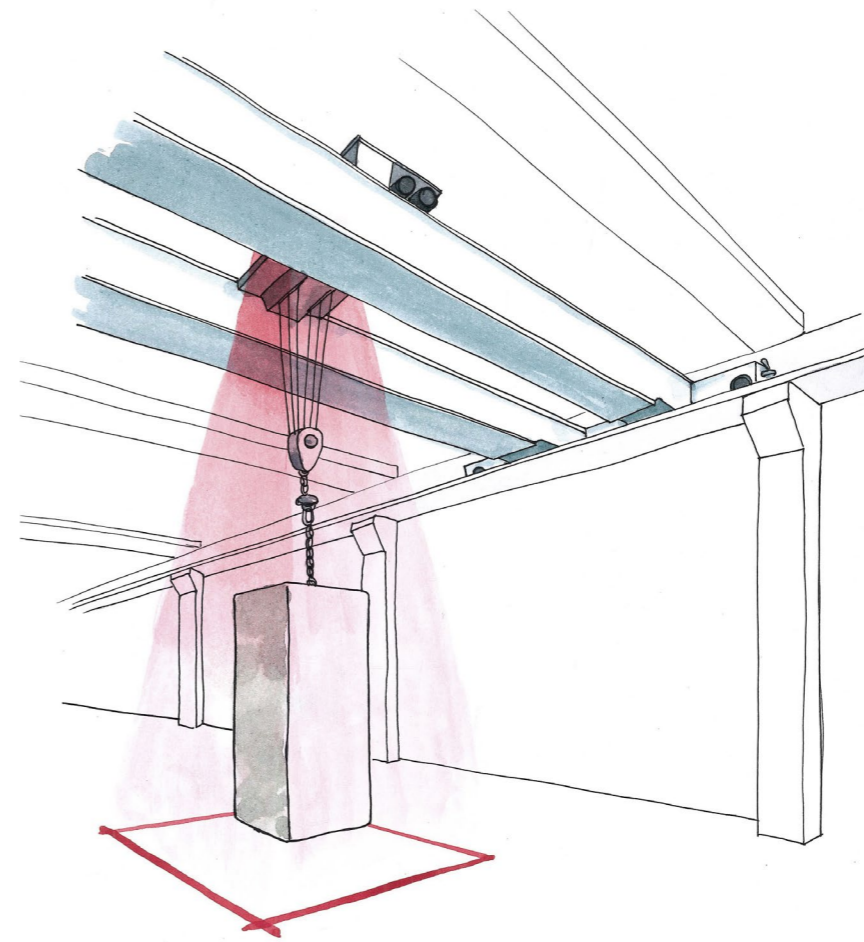

The sturdy and weather-resistant design makes these projectors suitable for both outdoor and indoor use, ensuring **OPTIMAL PERFORMANCE** in all conditions.

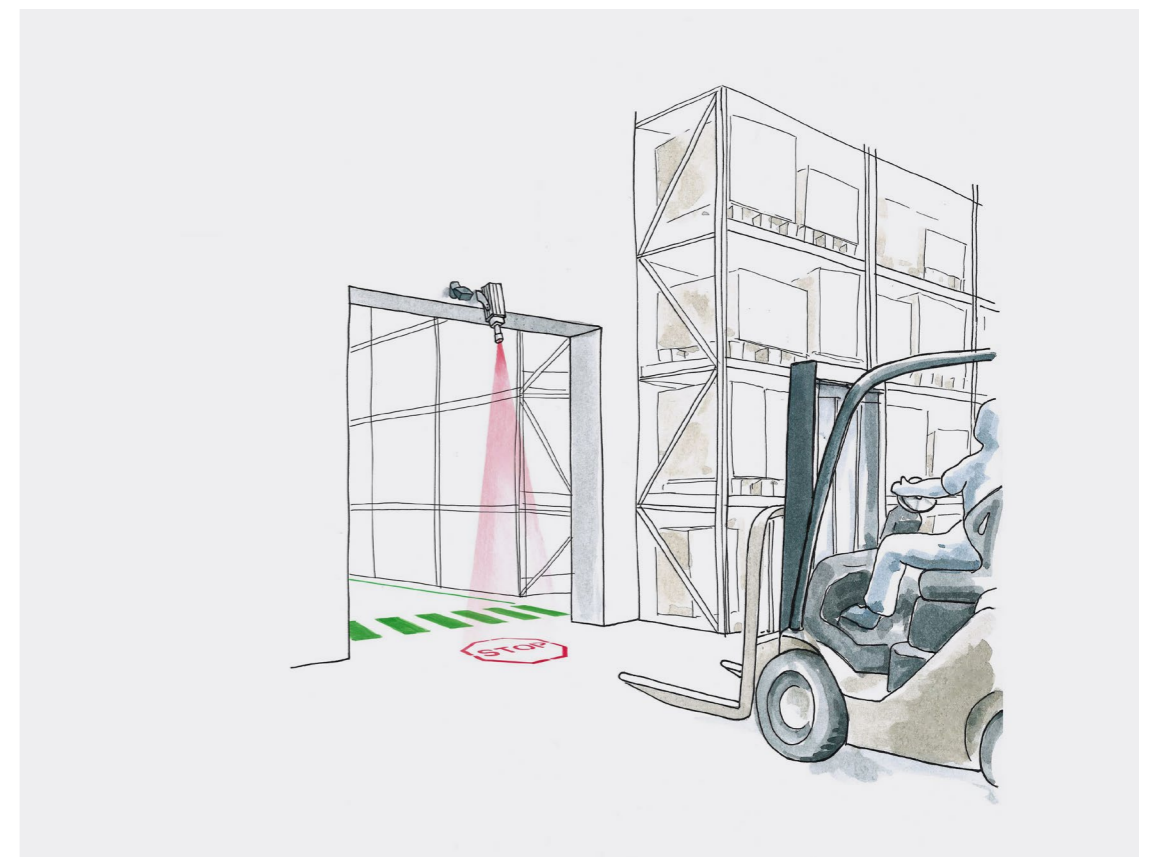

road signs applications

DESTEVI SOLUTIONS are FLEXIBLE and VERSATILE and can also be used in other applications.

The DELAS and DEGOB projectors, for instance, can also be used in ROAD SAFETY: such as for signaling pedestrian crossings and to project road boundary lines.

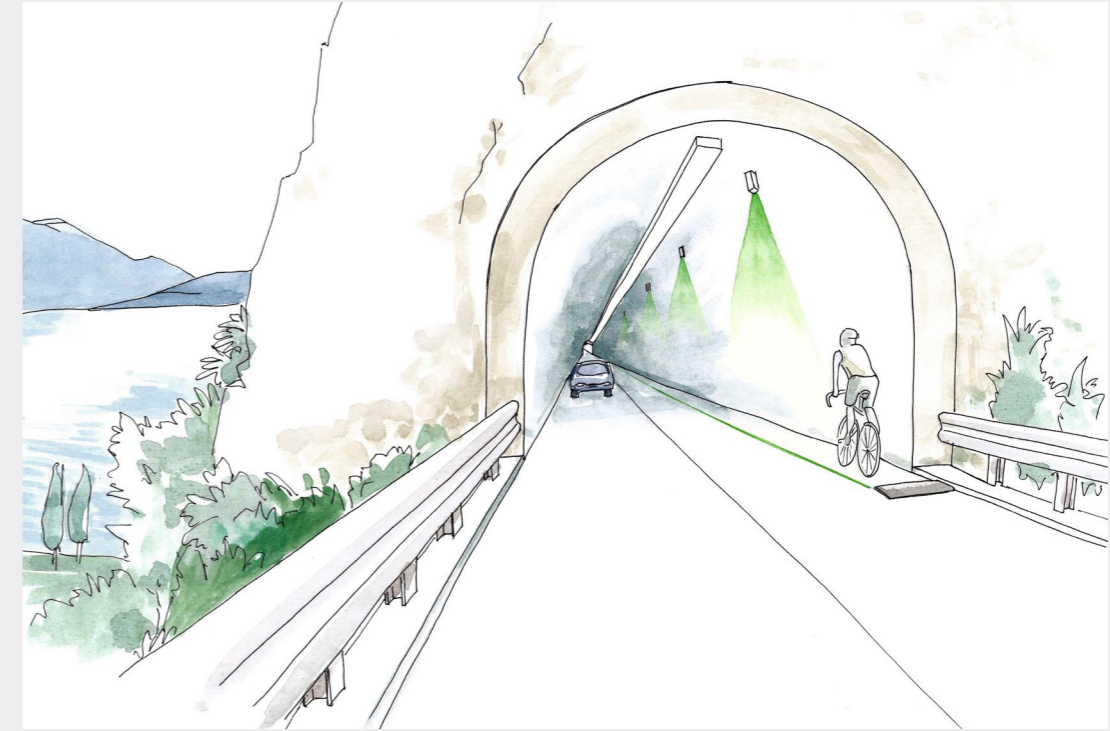

civil signs applications

DELAS and DEGOB line and symbol projectors can also be used for civil applications, such as signalling pedestrian paths or escape routes inside hospitals, nursing homes, shopping centres and more.

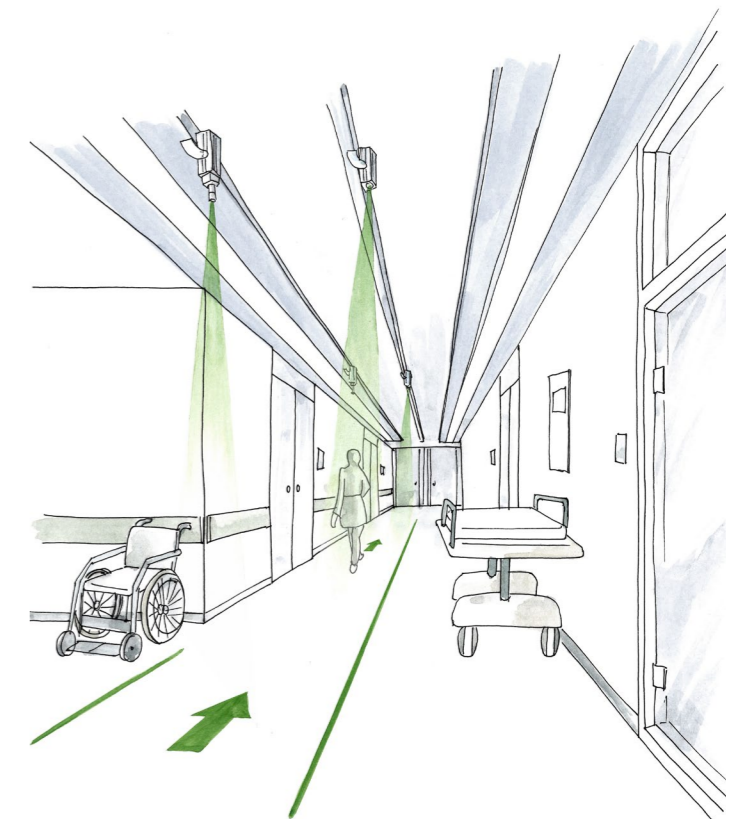

advantages

These projection systems are developed **TO IMPROVE AND SOLVE CRITICAL SAFETY** and organizational problems in different sectors.

The advantages can be divided into two main categories: those compared to traditional solutions, such as tape or paint on the floor, and those compared to competitors products.

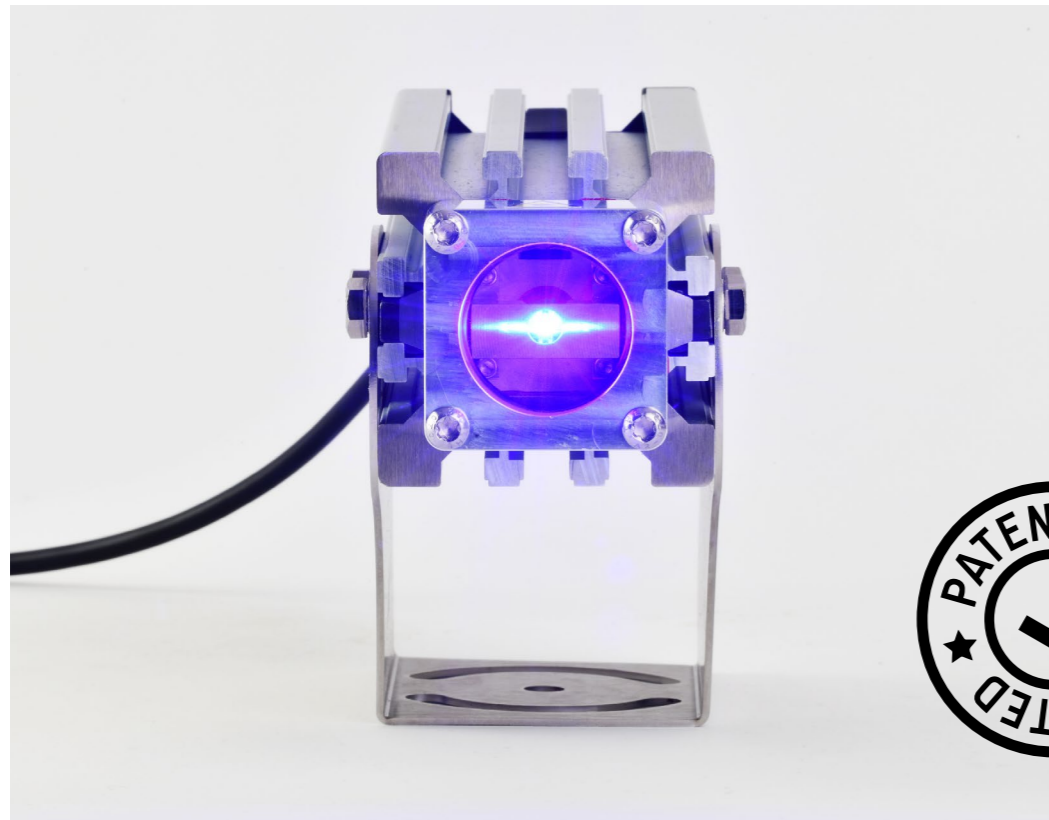

DELAS projector

up to 30 meters
of line with only
1 projector

DESTEVI allows the installation of a quarter of the number of projectors needed by competitors to cover the same length of projected line.

80%
energy savings

Our projector systems consume only one-sixth as much energy as competitive products.

cost
reduction

The cost of the projectors and their installation is unique, and no maintenance is required compared to traditional solutions.

100%
made in Italy

All our products are made in Italy, with great attention to details, materials used and packaging.

80%
recycled materials

All our products are made from recycled materials.

100%
tested products

All our products are tested to ensure the highest quality and efficiency.

modularity and
configurability

Modular signage paths that can be adapted to changing environments.

DELAS, DELED & DELAS SQUARE, line projectors for overhead cranes and moving elements

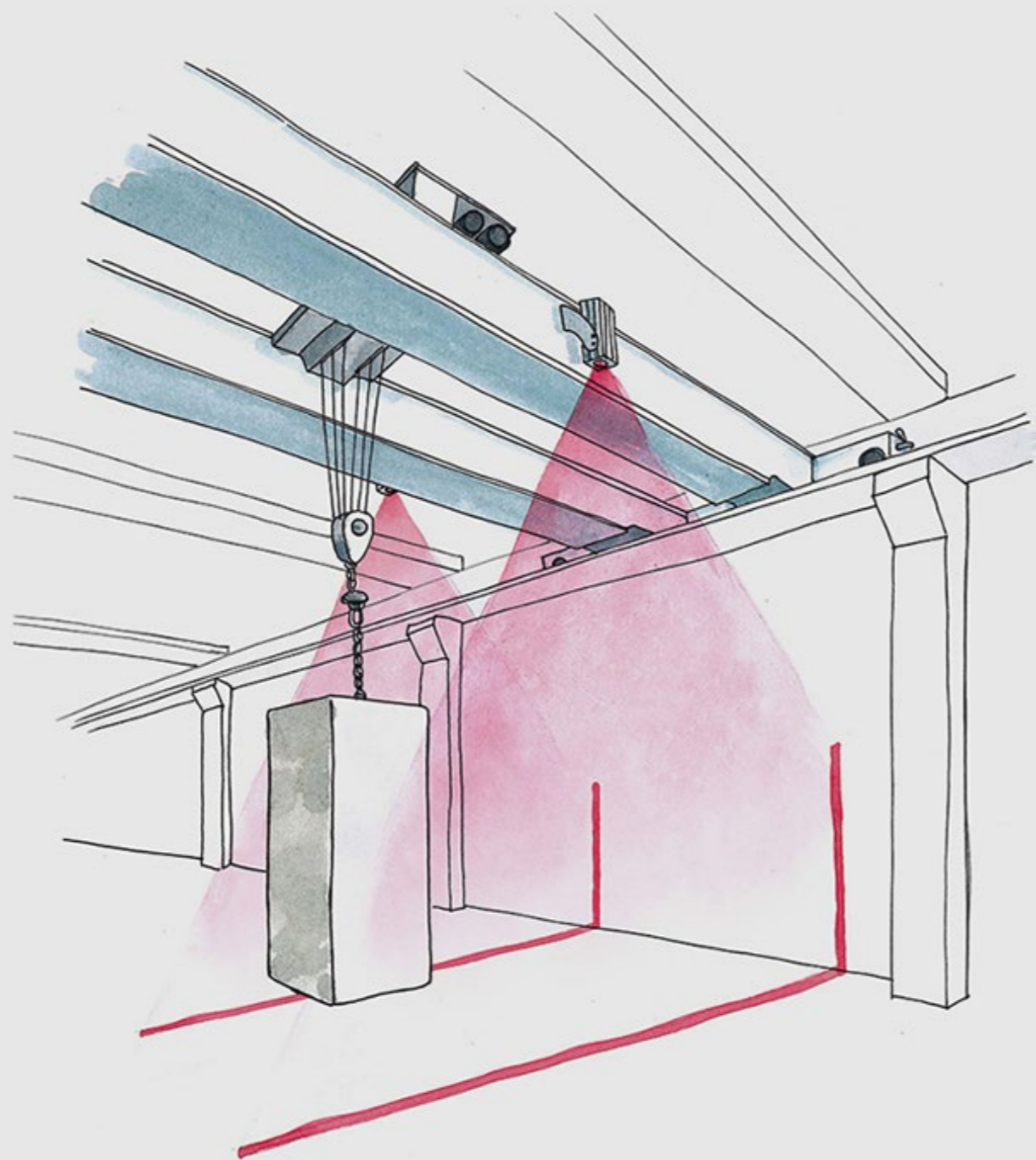

DELAS projector

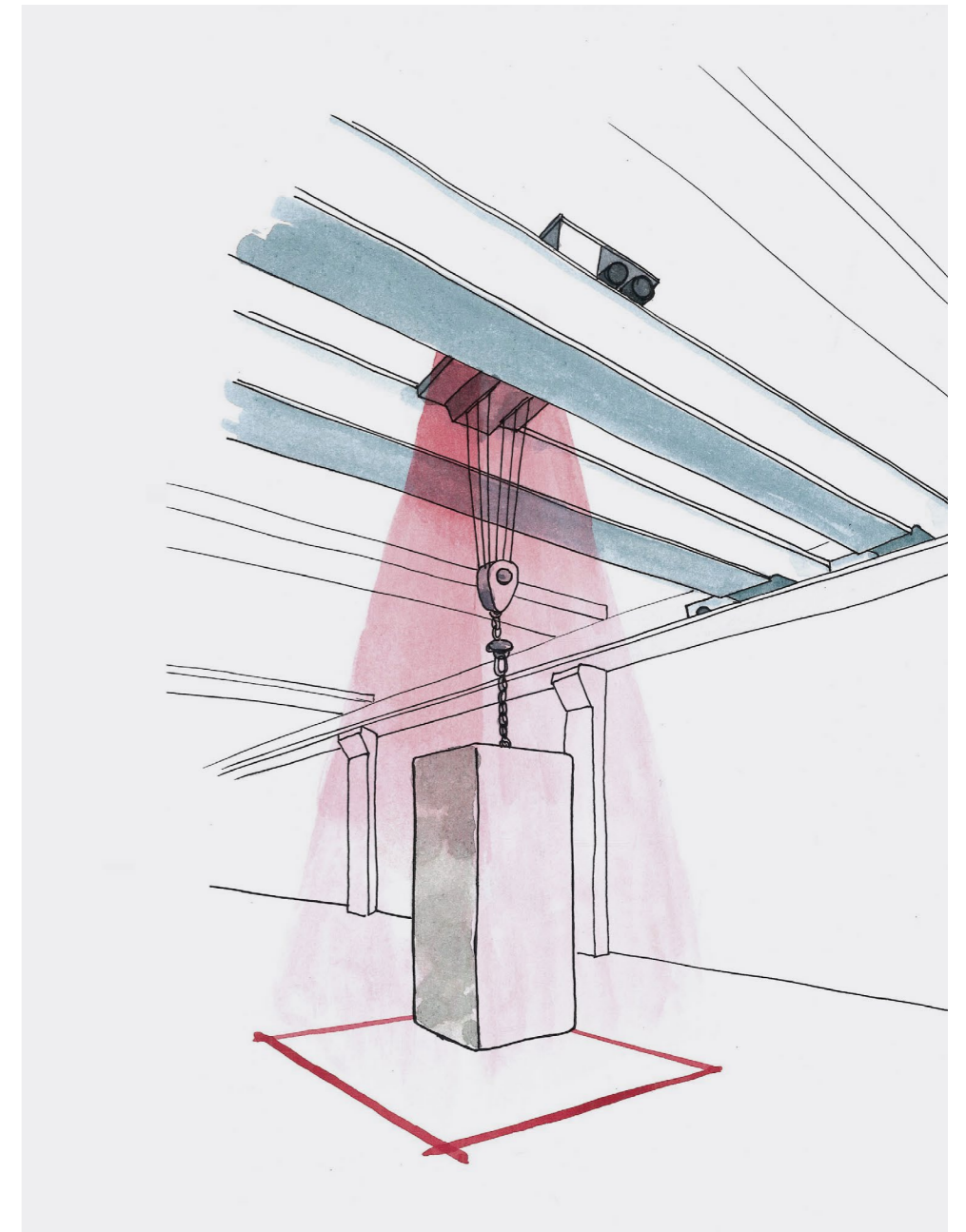

DELAS SQUARE projector

With high-quality components and a **HIGHLY EFFICIENT** laser light source, the **DELAS, DELED** and **DELAS SQUARE** projectors are the perfect solution in all weather and lighting conditions.

Designed and engineered to ensure **CONTINUOUS OPERATION** and a long service life, these lighting systems guarantees the projection of lines that are always sharp and visible.

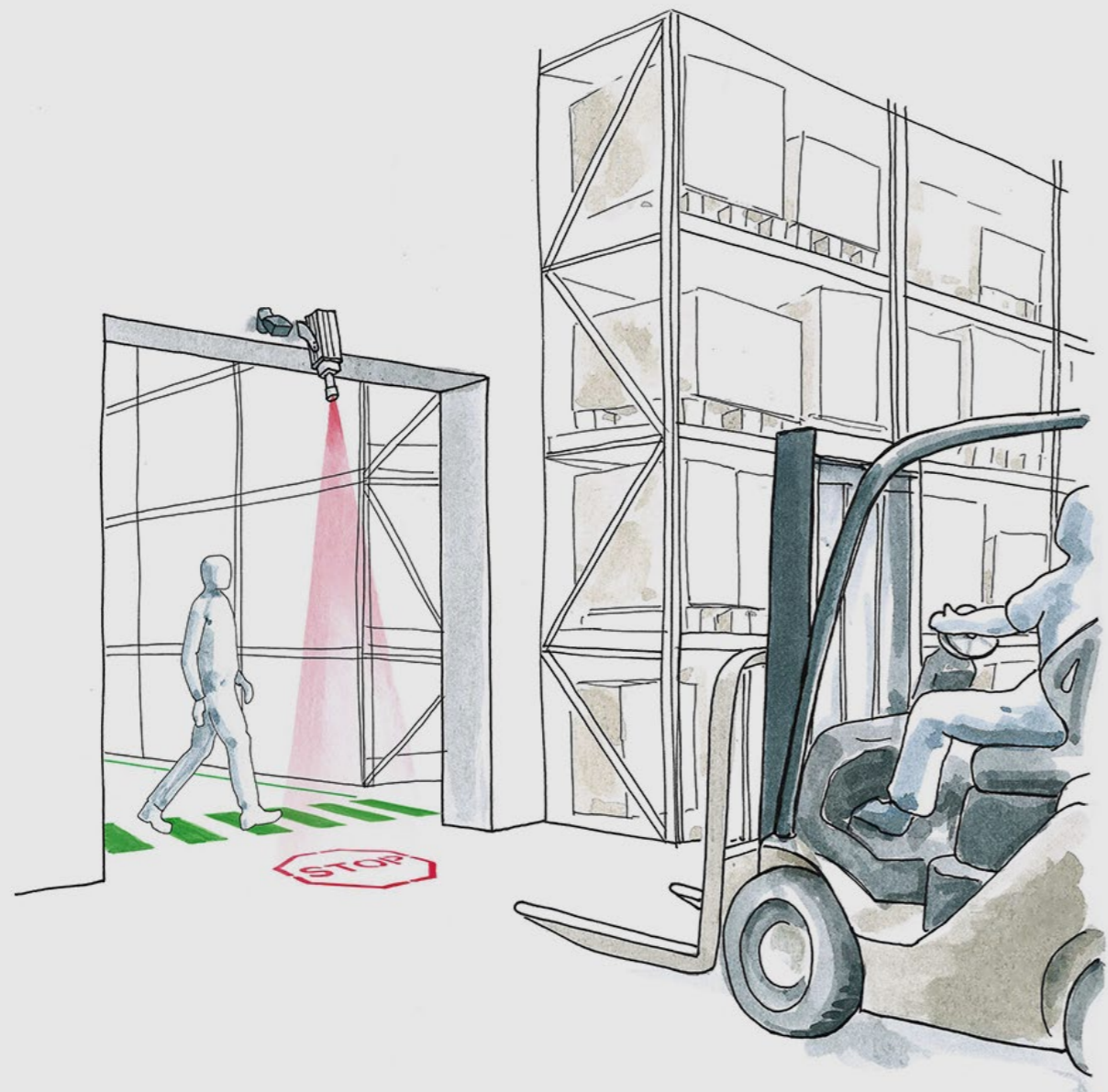

DEGOB, symbol projectors for multifunctional applications

One of the strengths of the DEGOB projectors is the **OPTIMIZATION OF ITS VISIBILITY**, in relation to the height of the installation, thanks to the adjustable front scope that allows the focus of the projected symbols to be calibrated.

DECARLINE & DECARPOINT, projectors for signalling lift trucks in motion

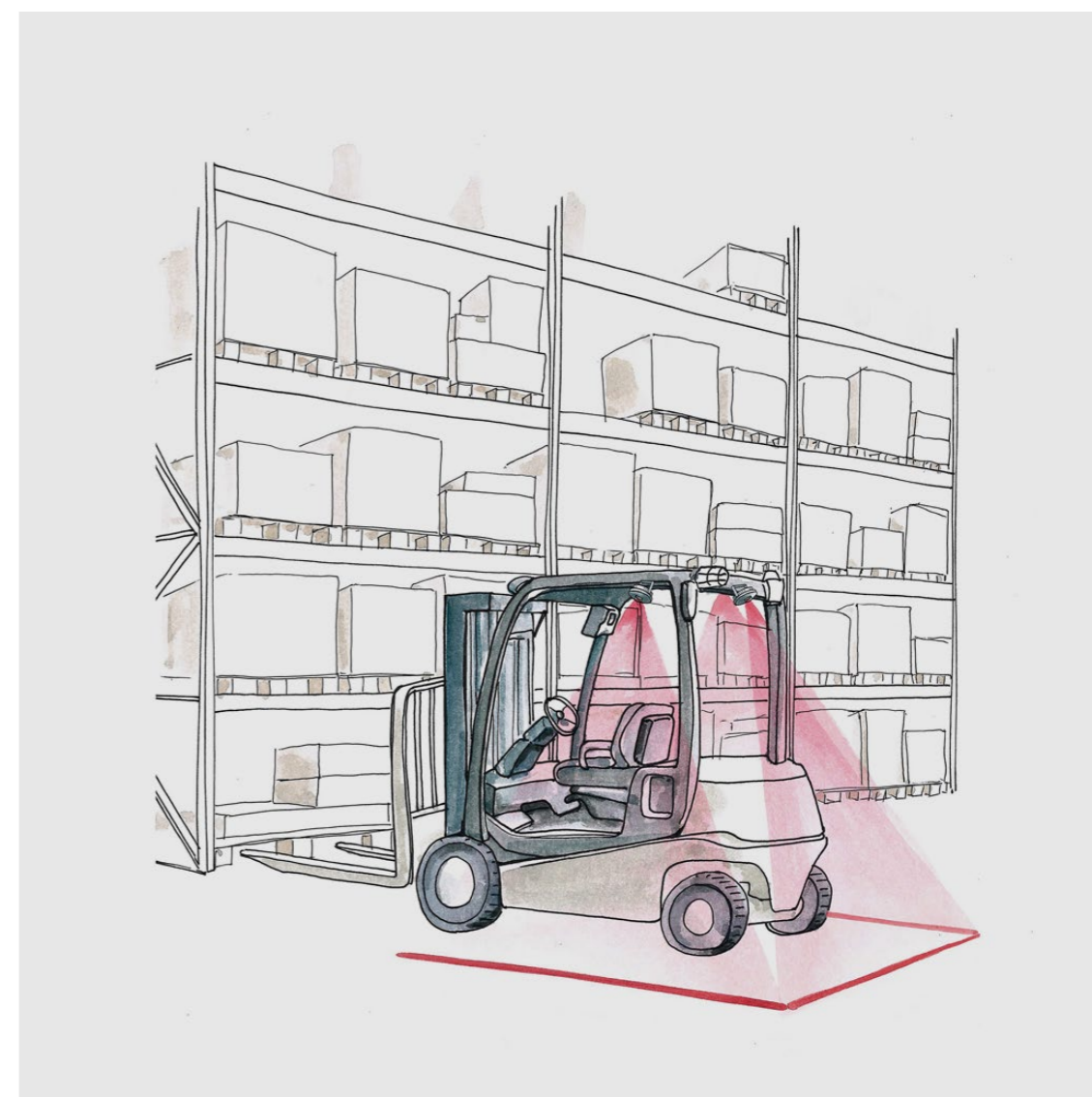

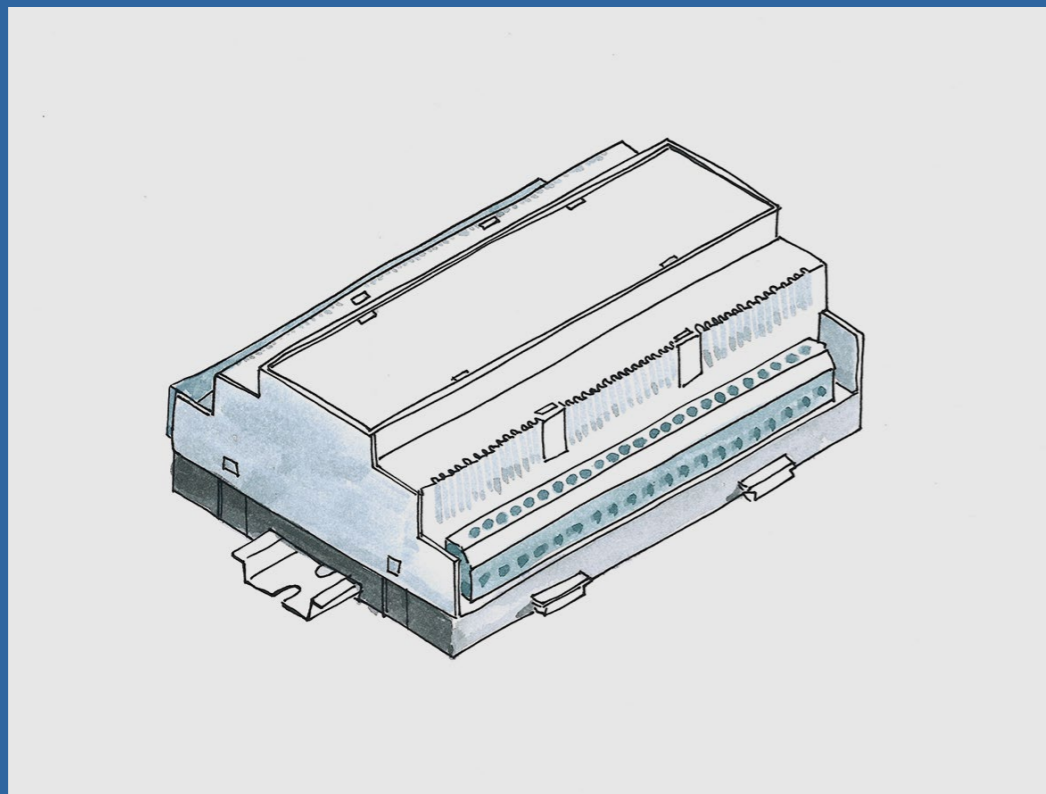

GENIUS, smart management systems for dynamic projectors signage

GENIUS is the centralised management system with presence sensors specifically developed for dynamic projector management.

These centralised management systems are developed to improve safety, efficiency and organisation in the workplace, specifically in the industrial sector.

An automatic safety signage management system that not only integrates perfectly with spaces, but is also intuitive and immediate.

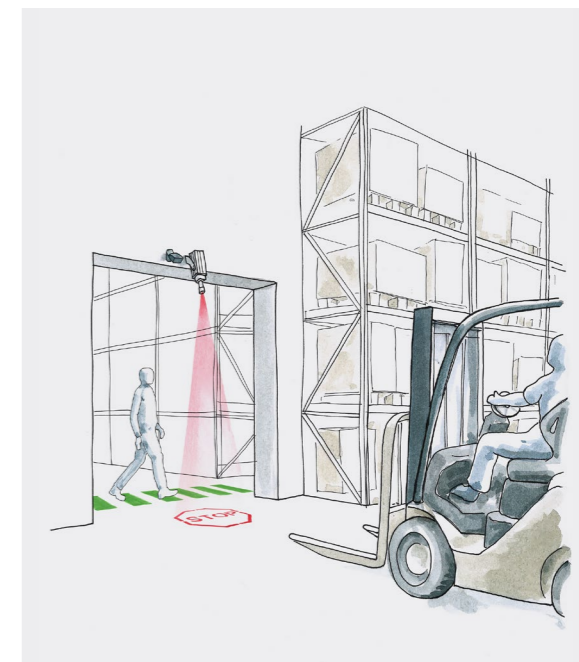
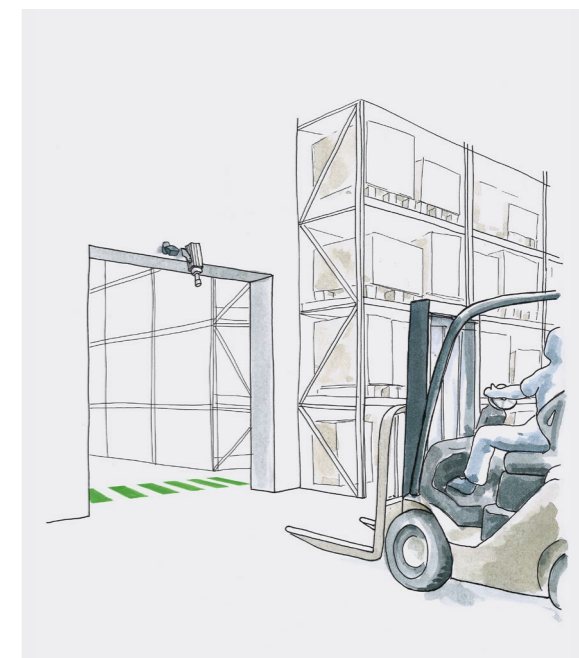
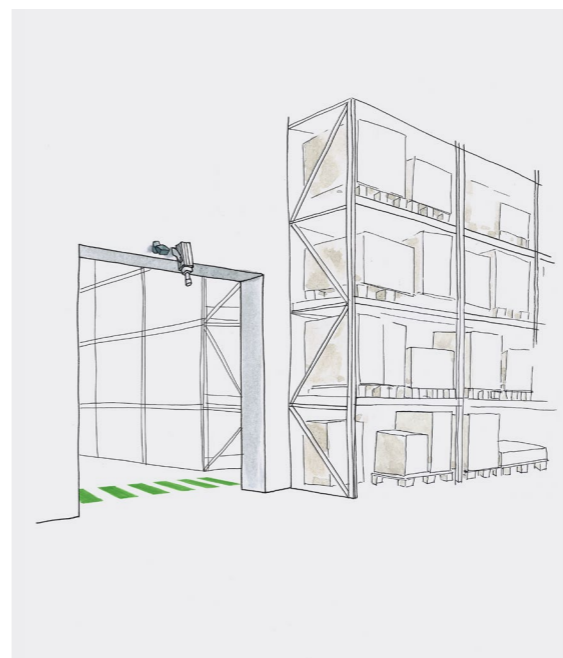

DESTREVI srl

Via Statale, 5 - 25011 Calcinato (BS) - ITALY

T +39 030 913 3570

info@destevi.it

destevi.it

#destevi

